

92153
AUSCO AMERI-TORQUE™
MECHANICAL CALIPER RETROFIT
INSTALLATION INSTRUCTIONS
For Club Car, Yamaha*, Star and Columbia Par Car
 Kit #'s: PK.1999, PK.2021

Kit contents:

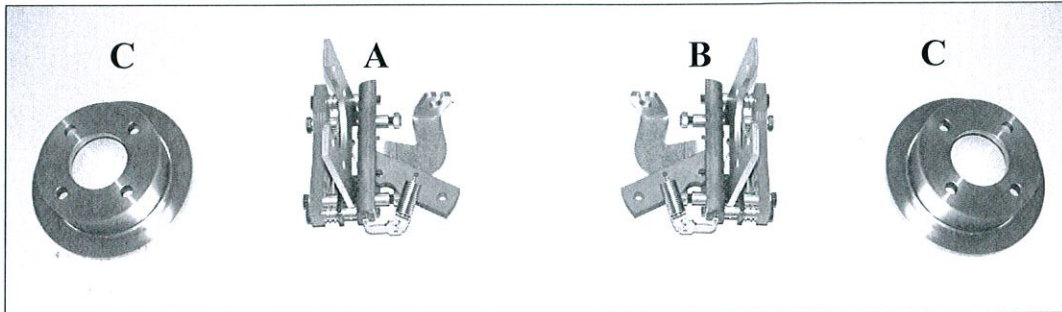

Item	Qty	Description	Item	Qty	Description
A	1	Left Caliper with mount	C	2	Rotors
B	1	Right Caliper with mount			

***Yamaha applications** require two washers to be installed on cables (not included in this kit). See **page 15** before starting this installation.

This kit requires wheels that are 10 inches or larger in diameter. Standard 8 inch wheels will not fit over these brakes.

The latest instruction manuals and service bulletins are available at www.auscoproducts.com.

Note: When removing the original brakes, save all fasteners (Pins, Clips, Cotter keys, Cable clips, Nuts, Bolts, and Washers.)

WARNING: The Ameri-Torque Brake is designed for off-highway vehicle applications only, which meet all of the following criteria:

- DO NOT EXCEED 25 MILES PER HOUR
- DO NOT EXCEED 2,400 POUNDS GROSS VEHICLE WEIGHT
- TIRES DO NOT EXCEED 25 INCHES TOTAL OUTSIDE DIAMETER
- DO NOT REQUIRE REGISTRATION FOR ON-HIGHWAY USE

CAUTION: Read the Installation Instructions completely before starting installation. Follow these Installation Instructions carefully. Proper braking is critical for safe operation of your vehicle. It is recommended that installation of the Ameri-Torque Brake Kit be performed by a trained mechanic. Test drive the vehicle carefully in an open area and adjust brake actuation cable as needed to achieve satisfactory braking function.

WARNING: Always conduct a visual inspection and evaluate pedal travel before operating vehicle to verify that some braking function is present. All driving tests must be done in a safe location with regard for all persons.

Installation Instructions

1. Remove wheel and old brake drum. (see Fig. 1)

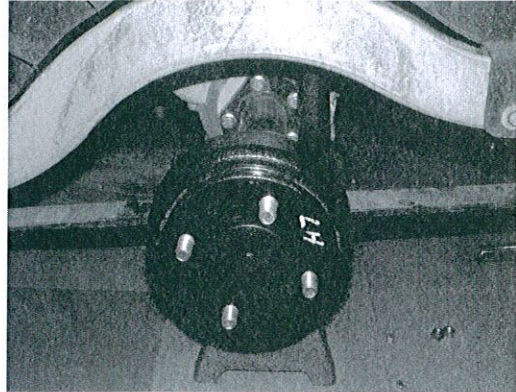

Fig. 1 Original drum brake

2. Remove the axle shaft per vehicle manufacturer's instructions. Remove brake assembly from vehicle by removing the four small bolts that attach the assembly to the axle. Save all fasteners. (See Fig 2)
3. Disconnect the cable from the brake and the cable bracket and save the cable clips and pins.

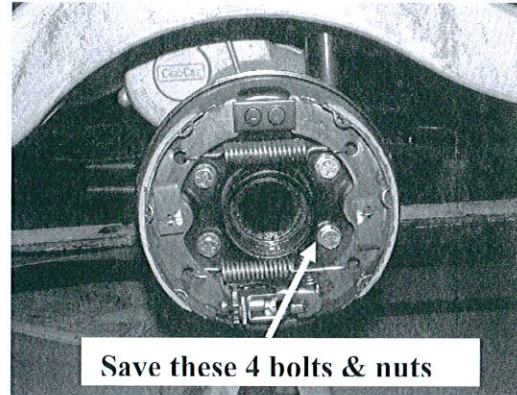

Fig 2 Original drum brake assembly

4. Club Car only: With a saw or other cutting tool, cut the cable bracket tab off of the spring bracket at the bend. (See Fig 3)
Note: on lifted Club Car vehicles, you can turn the spring bracket so that the cable tab is in the rear instead of cutting.
5. Re-install axle shaft per vehicle manufacturer's instructions.

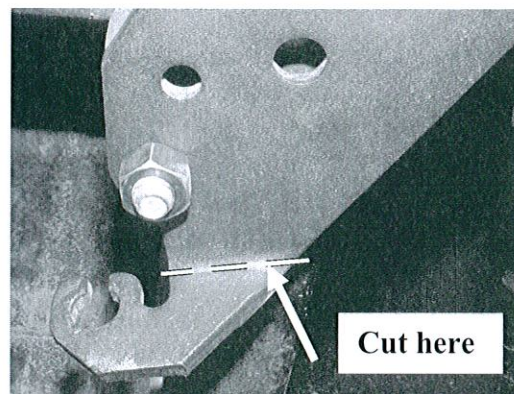

Fig 3 Original cable bracket

6. On each new caliper assembly, remove the mounting bracket by removing the bolts and spacer sleeves. (See Fig 4)

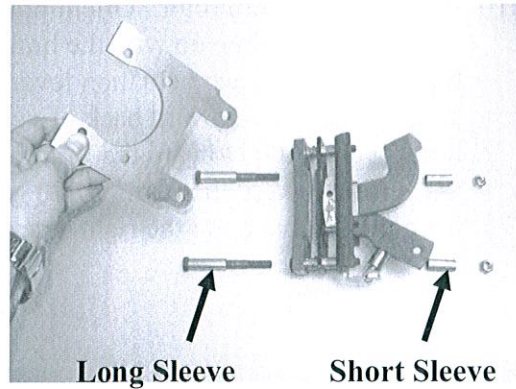

Fig 4 – remove mount bracket

7. Install new brake mounting bracket facing downward onto outside of axle tube bracket. Use the 4 bolts and nuts that were removed in step 2, head of bolt facing outward. Tighten to 18-20 ft-lbs (See Fig. 5)

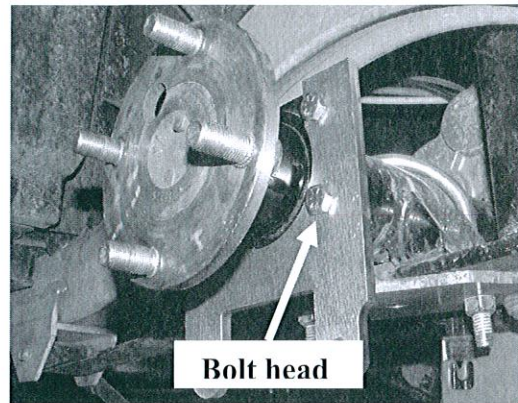

Fig. 5 Installed caliper mounting bracket.

8. Mount rotor over hub. For temporary holding while brake is being installed, finger tighten (2) wheel nuts over hub. (See Fig.6)
9. Determine which caliper is left and which is right. (See the Content's photo at beginning of instructions)

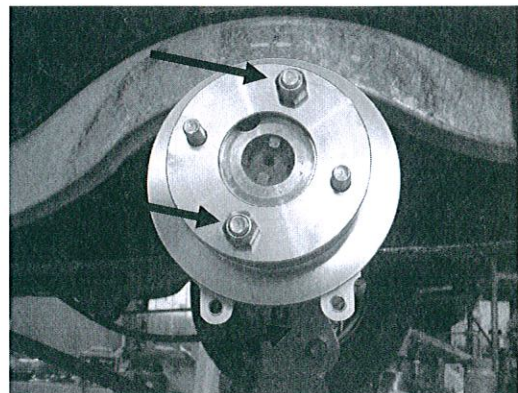

Fig. 6 - (2) lug nuts to temporarily hold rotor in place.

10. Install caliper onto rotor. Orient brake so that mounting holes line up with the brake mounting bracket. Brake lever actuation lever and spring are to be oriented toward back of vehicle. Cable bracket should be toward the front of vehicle and spring toward the rear. If not, you may have the left brake on the right side.

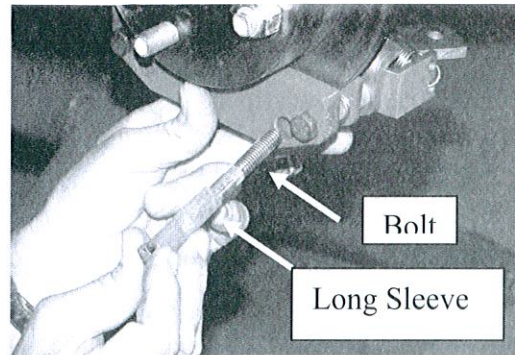

Fig. 7 - front view

11. Insert bolt in long sleeve then install bolt with sleeve through front of caliper. Push bolt and mounting sleeves thru holes in brake until they hit the mounting bracket. Install short sleeve and nut over bolt on the back of caliper. Tighten nut to 20-25 ft-lb. (See Fig.'s 7 & 8)
12. Verify that brake caliper is sliding freely on mounting sleeves by pushing the caliper back and forth.

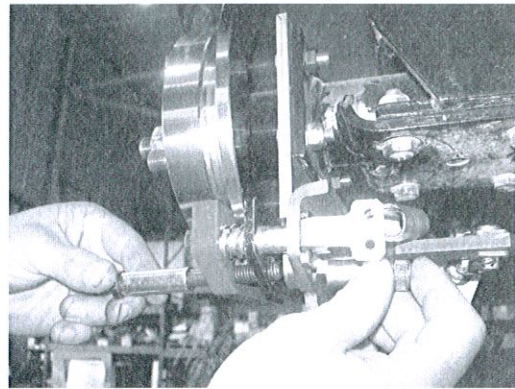

Fig. 8 - Back view of caliper.

13. Anchor brake cable conduit fitting to cable bracket provided on brake caliper. On DS cars use retaining ring from previous drum installation to keep it in place. (See Fig. 9) On Precedent cars cable has a built-in retainer. (See Fig 10)

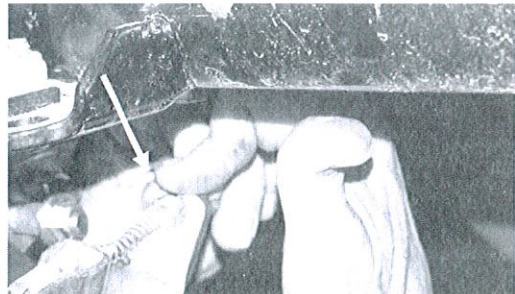

Fig. 9 – DS cars - Installing retaining clip

Attention: Yamaha applications require modifications to the cable and added washers (not included in this kit). See page 15 for Technical Service Bulletin 92433.

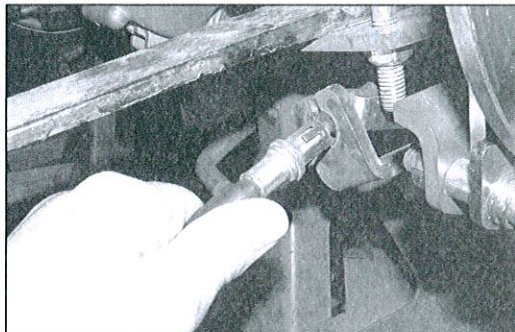

Fig 10 – Precedent cars - Installing cable

14. Attach cable end to hole on the end of brake actuation lever with original clevis and hitch pin. (See Fig. 11) You may need to loosen the cable at the pedal linkage to have enough slack to install pin.

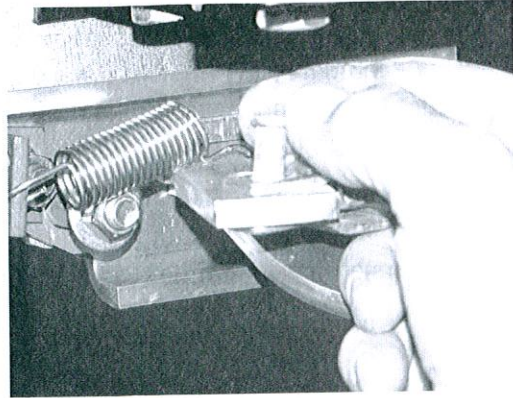

Fig. 11 - Attach brake cable to lever

To Loosen cables:

DS cars: (See Fig 12)

- a. First loosen the locking nut on the linkage rod.
- b. Then loosen the large adjustment nut.

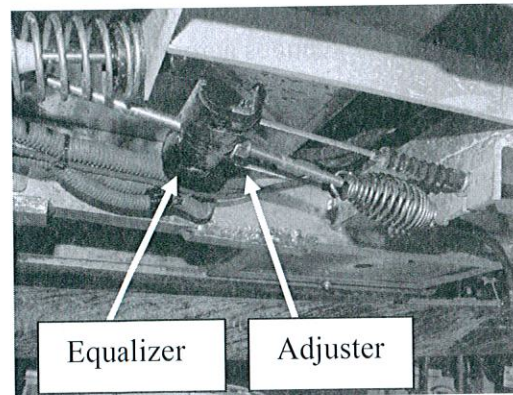

Fig. 12 – DS Cars – cable adjustment.

Precedent cars: (See Fig 13)

- a. LH nut has reverse threads. To loosen, stand at driver's side of car and pull toward you.
- b. RH nut has standard threads. To loosen, stand at driver's side of car and pull toward you.
- c. Turn the adjuster to loosen cables.

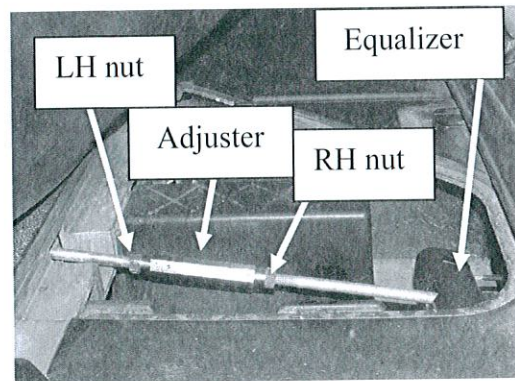

Fig 13 – Precedent cars – cable adjustment

15. Repeat steps 1-14 for other brake.

16. Adjust brake cable tension so that brake pads drag against rotor. Then firmly actuate brake pedal a few times. Loosen brake cables just enough that the rotors spin freely. Firmly actuate pedals each time you make an adjustment. Cables should be tight enough for good pedal feel but not cause brake drag. If you do not have enough adjustment left, you may add washers to the adjuster rod at the equalizer bar.

Suggested running clearance to rotor is 0.003” to 0.005”. Check running clearance on both calipers at the same time (use 2 feeler gauges).

- a. Insert feeler gauge between back of rotor and inside brake pad in the center of the pad. (See Fig. 14)
- b. You should have some resistance but still be able to move the feeler gauges across the full width of the pad.

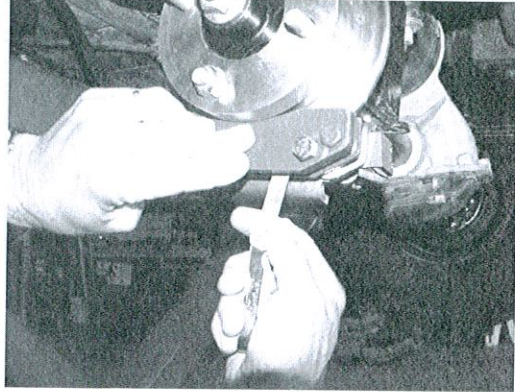

Fig. 14 Check pad clearance of both wheels at the same time.

17. Remove the feeler gauges and verify that brake caliper is sliding freely on mounting sleeves by pushing the caliper back and forth.
18. Check pedal feel. Re-adjust brake cable as necessary. Verify that brakes do not drag. Tighten the cable linkage lock nut/nuts against the adjustment nut.
19. Remove the two temporary holding nuts from hubs.
20. Install wheels and tighten wheel nuts per vehicle manufacturer's recommendation.
21. Verify wheel does not contact brake. (See Fig. 15)
22. Carefully drive the vehicle to check pedal feel. Re-adjust brake cable as necessary. Verify that brakes do not drag.

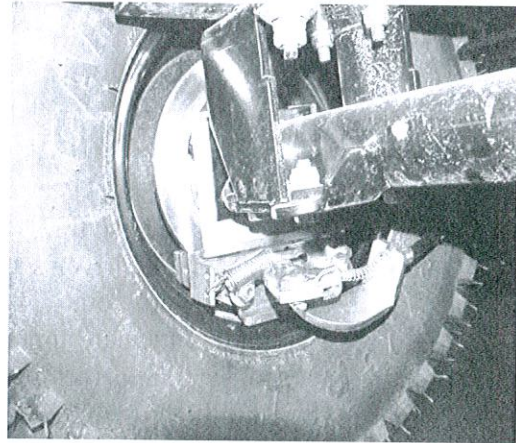

Fig 15 – Brake inside wheel

CAUTION: Test-drive the vehicle carefully in an open area and adjust the brake actuation cable as needed to achieve satisfactory braking function. Brakes will need time to break in. Brakes may need re-adjustment after the first few hours. If you experience noise while driving, loosen brake cables and re-check pad clearance. Satisfactory brake performance does not eliminate the need for routine brake testing and inspection. Continued proper brake operation depends on periodic maintenance.

WARNING: Always conduct a visual inspection and evaluate pedal travel before operating vehicle to verify that some braking function is present. All driving tests must be done in a safe location with regard for all persons.

For questions, concerns, problems, comments, please contact your local dealer.

Maintenance

WARNING: The caliper must be inspected for wear periodically. To protect rotor from damage, there will be substantial material left on pads when replacement is required. Do not shim this brake. Do not use lining thickness as a measure of pad replacement. Use the following procedure to determine need for replacement.

- a. If the vehicle is not on its wheels, be sure it is properly supported with jack stands.
- b. Have an assistant apply brake pedal fully and hold during inspection. (For reference, this should be about 125 lbs applied to the pedal.)
- c. Check on both calipers that there is at least $\frac{1}{4}$ " of cable showing between the yoke and housing. (See Fig M1) (If there is a rubber boot over the cable, pull it back.)
- d. If there is less than $\frac{1}{4}$ " you must replace your brake pads (see page 11).*

* It is normal to still have material on the pad even if the above inspection indicates replacement is required. This is by design to protect the brake rotor from damage. Always replace brake pads on both the left and right brake assembly.

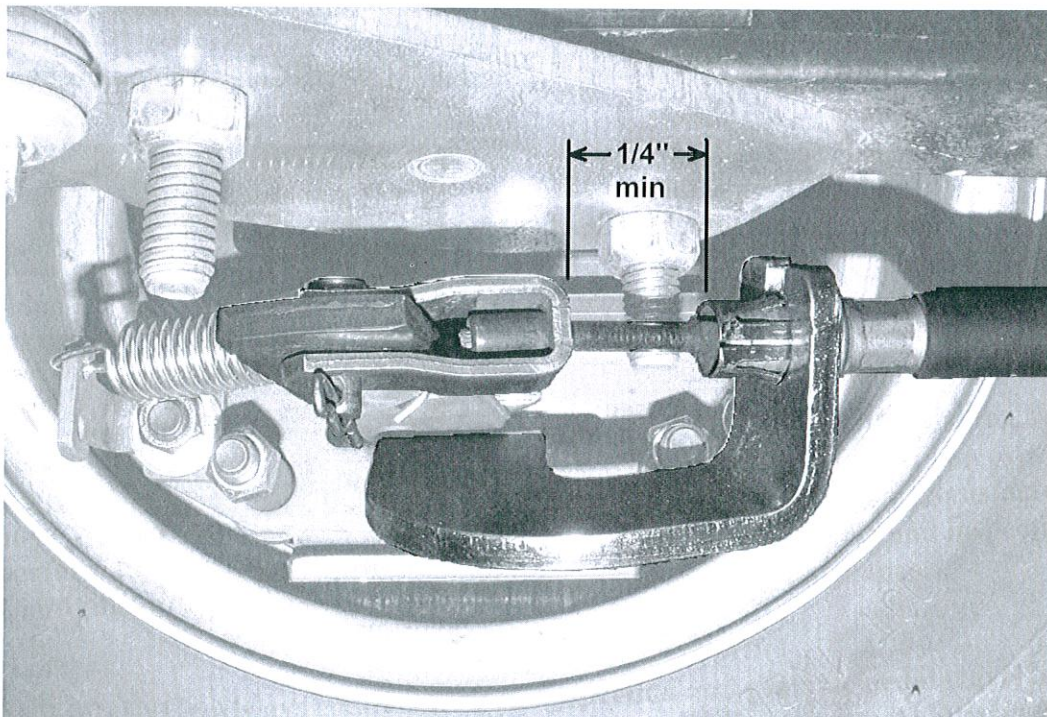

Fig M1 – Determining pad replacement



Ausco Ameri-Torque Brakes - Technical Service Bulletin 92432
Attention: All Ausco Ameri-Torque Brake Applications

Subject: Clarification of pad replacement requirements.

The caliper must be inspected for wear periodically. To protect rotor from damage, there will be substantial material left on pads when replacement is required. Do not shim this brake. Do not use lining thickness as a measure of pad replacement. Use the following procedure to determine need for replacement.

1. If the vehicle is not on its wheels, be sure it is properly supported with jack stands.
2. Have an assistant apply brake pedal fully and hold during inspection. (For reference, this should be about 125 lbs applied to the pedal.)
3. On both brake calipers, check that there is at least $\frac{1}{4}$ " of cable showing between the yoke and housing.
(If there is a rubber boot over the cable, pull it back.)
4. If there is less than $\frac{1}{4}$ " you must replace your brake pads.*

* It is normal to still have material on the pad even if the above inspection indicates replacement is required. This is by design to protect the brake rotor from damage.

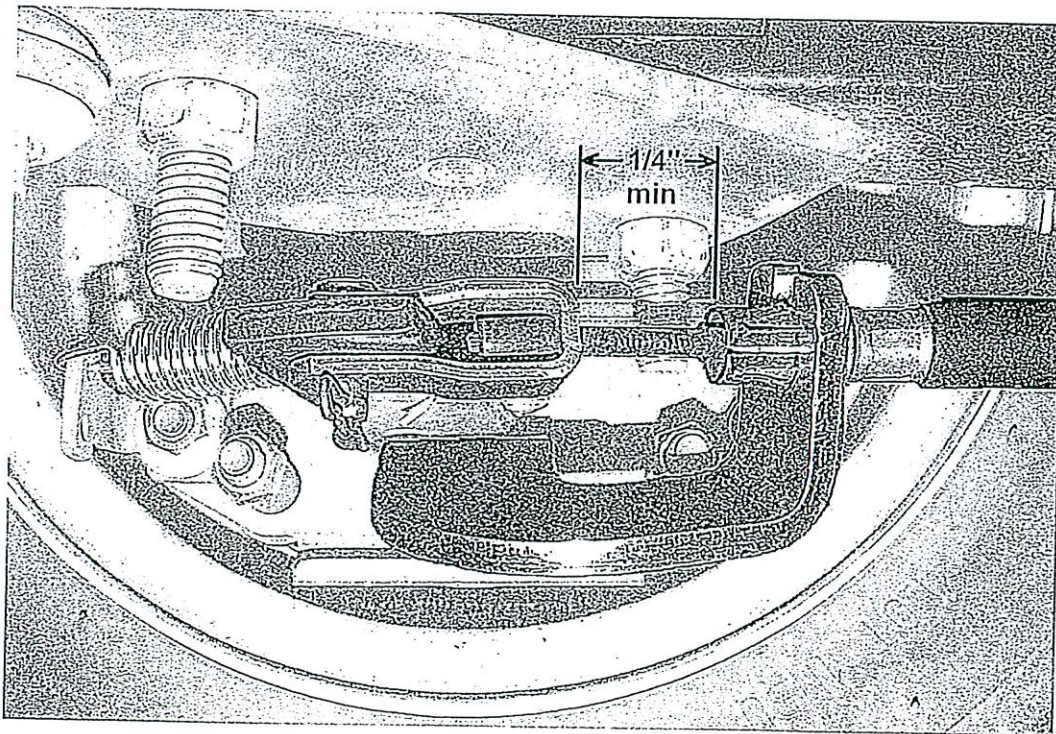

REVISION HISTORY:

Sym.	Description	ECO	Date
A	Initial Release	25852 ELC	03/16/10

Attention: Yamaha Applications

Subject: Improved installation procedure instructions for Yamaha applications.

I. The factory cable return spring is unnecessary with Ameri-Torque brakes and limits brake wear and travel. The spring must be removed to insure full brake lever travel.

1. Pull back the rubber boot to access the spring.
2. Grab the end of the spring coil with needle nose pliers.
3. Pull the spring end. The spring wire will unwind off of the cable.

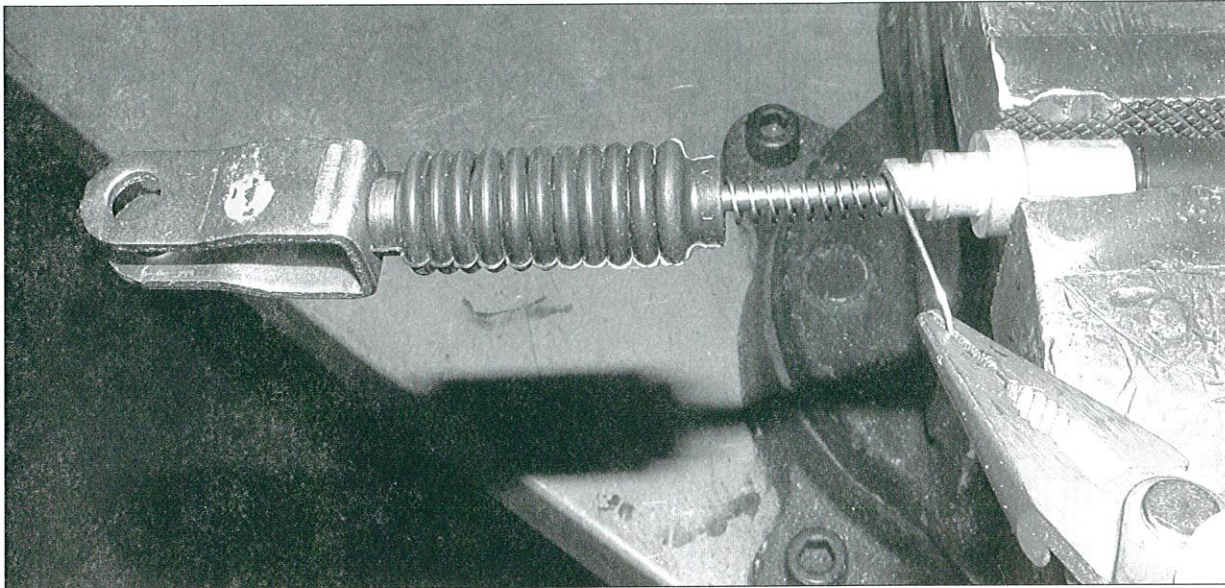

II. The Yamaha cable housing is smaller than most other applications. To prevent brake performance degradation, a retaining washer must be added (not included in the kit). Use the following procedure to make and add two washers.

1. Acquire two 3/8 inch flat washers. (1/16" to 1/8" thick)
2. Cut a slot in each washer, 3/16" wide to pass over inner cable.
3. Install washer on each cable then install cable to brake.

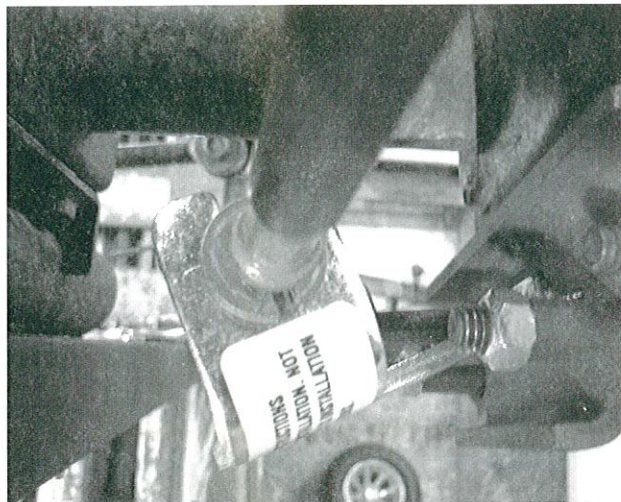
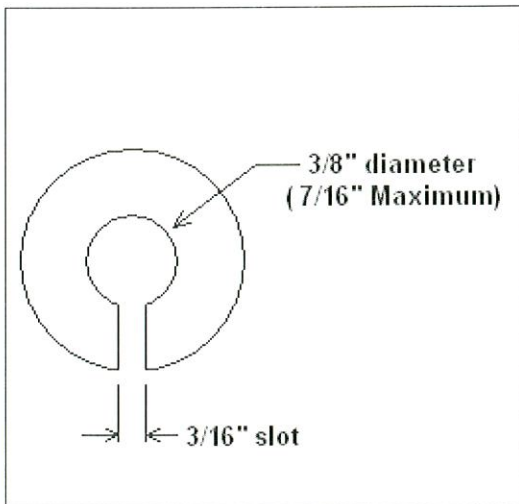

REVISION HISTORY:

Sym.	Description	ECO	Date
A	Initial Release	25852 ELC	03/16/10

